

Induction Motor

12 Watt

Frame Size: □ 65 mm

Continuous Rating, TE Aluminium Body.
Rotates in Clockwise or Counter Clockwise Direction.
Capacitor Cover or Open Lead Wires for Connection.

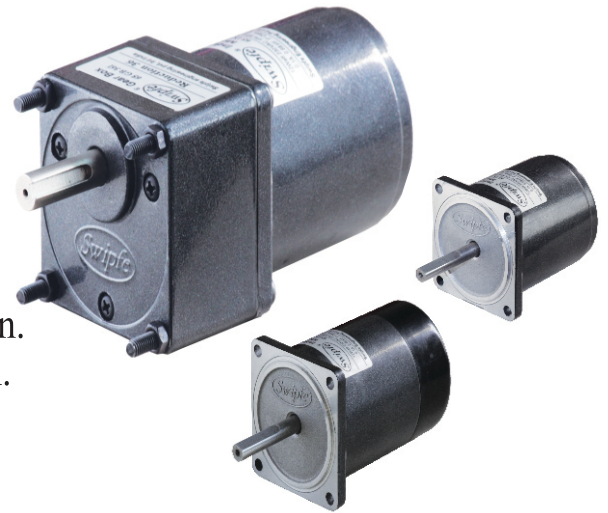

Specifications:

Model	Supply Voltage	Frequency Hz	Current A	Starting Torque N.m	Rated Torque N.m	Rated Speed RPM	Capacitor μF
65 IW 2□ 12	Single Phase 110V	50	0.30	0.03	0.045	2400	3.0
65 IX 2□ 12	Single Phase 230V	50	0.15	0.03	0.045	2400	1.0
65 IW 4□ 12	Single Phase 110V	50	0.30	0.06	0.09	1200	3.0
65 IX 4□ 12	Single Phase 230V	50	0.15	0.06	0.09	1200	1.3
65 IY 4□ 12	Three Phase 230V	50	0.12	0.09	0.08	1350	—
65 IY 4□ 12	Three Phase 415V	50	0.07	0.09	0.08	1350	—

□ Type Of Shaft, G for Gear Shaft, R for Round Shaft

Gearmotor Torque Table:

The maximum permissible torque is 4 N.m

50 Hz: Two Pole Motor

Unit : N.m

RPM	1000	832	600	500	400	333	240	200	166	120	100	82	60	50	40	32	30	25	20	16
Gear Ratio	3	3.6	5	6	7.5	9	12.5	15	18	25	30	36	50	60	75	90	100	120	150	180
Output Torque	0.1	0.12	0.18	0.21	0.27	0.32	0.45	0.54	0.65	0.8	0.96	1.1	1.3	1.5	1.9	2.3	2.6	3.1	3.9	4.0

50 Hz: Four Pole Motor

Unit : N.m

RPM	500	416	300	250	200	166	120	100	83	60	50	41	30	25	20	16	15	12.5	10	8.3
Gear Ratio	3	3.6	5	6	7.5	9	12.5	15	18	25	30	36	50	60	75	90	100	120	150	180
Output Torque	0.21	0.26	0.36	0.43	0.54	0.65	0.91	1.1	1.3	1.6	2.0	2.4	2.9	3.5	4.0	4.0	4.0	4.0	4.0	4.0

The Gear boxes are sold separately.

A coloured background indicates gear shaft rotation in same direction as motor shaft.

A white background indicates gear shaft rotation in opposite direction to the motor shaft.

The speed of geared motor is calculated by dividing motor's synchronous speed by the gear ratio.

The actual speed is less than the displayed value, depending upon the load.

Characteristics, specifications and dimensions are subject to change without notice.

Dimensions:

Motor, Gearbox with Capacitor Cover

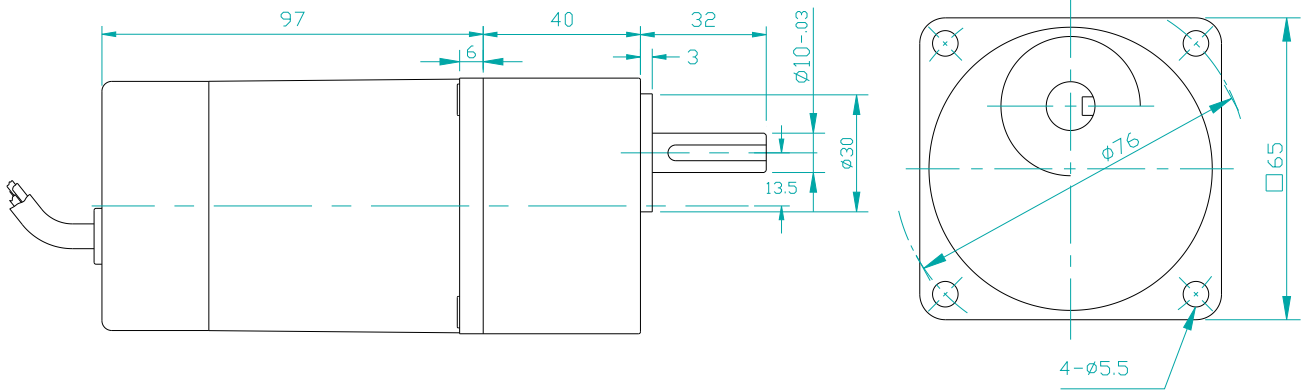

Motor Round Shaft with Capacitor Cover

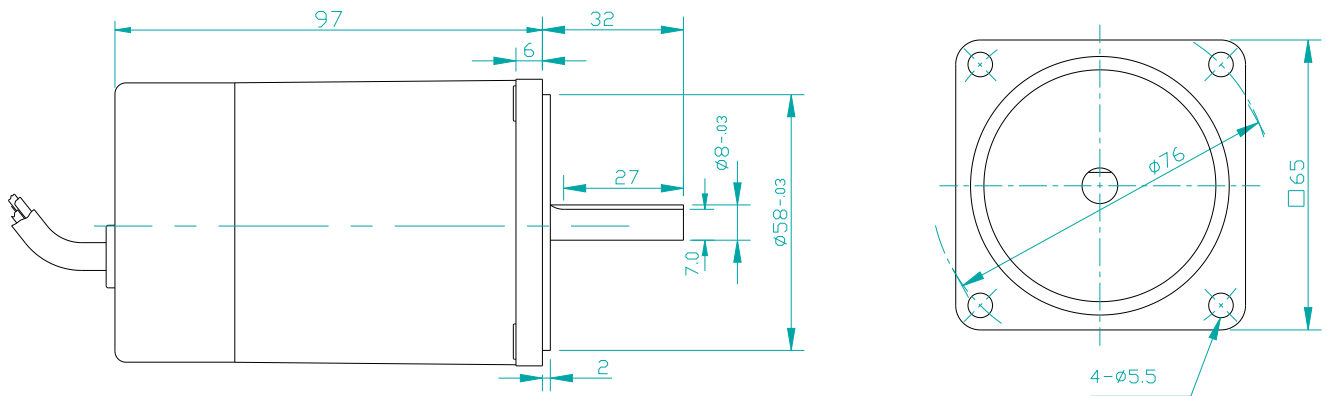

Motor, Gearbox with Lead Wires

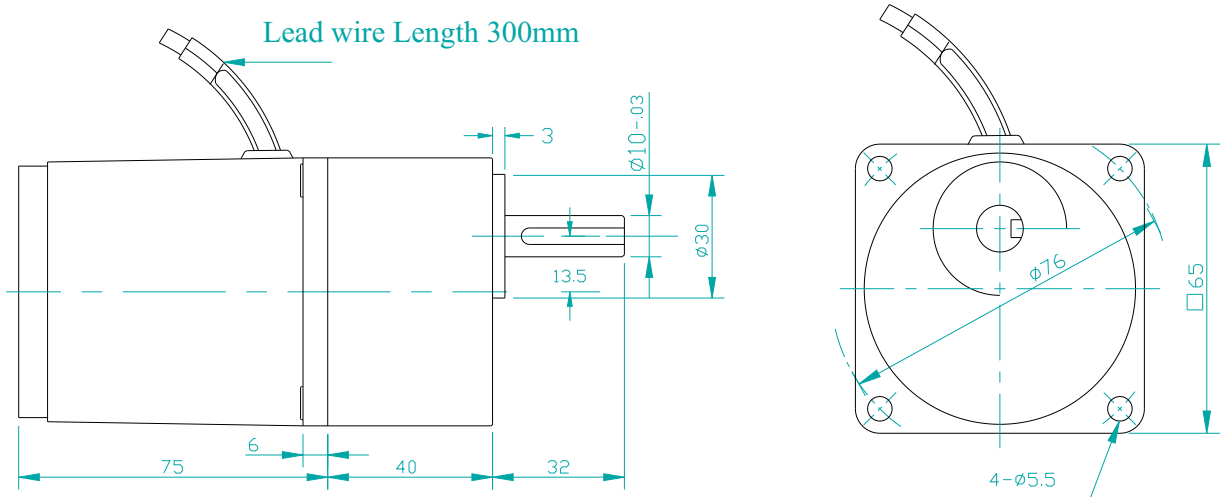

Key & Keyway

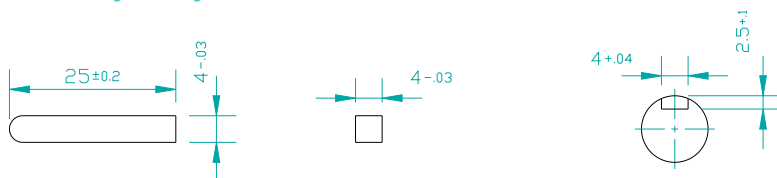

Weight: Motor 1.0 Kg

Gear Box 0.5 Kg

Induction Motor

Wiring Diagram: Capacitor Cover Type

<p>Single Phase Motor</p>	<p>Three Phase Motor</p>
<p>Capacitor is connected internally and is fitted in capacitor cover. Make the connections as shown to rotate the motor in clockwise direction. To Change the direction, flip CW to CCW.</p>	<p>Make the connections as shown to rotate the motor in clockwise direction To change the direction, interchange any two wire between U, V and W.</p>

Lead Wire Single Phase Motor

<p>Short Black wires and connect as shown to rotate the motor in clockwise direction To change the direction, flip CW to CCW.</p>	<p>Red wires are for running winding & Black wires are for starting winding. To change the direction, interchange Black wires or Red wires.</p>

Lead Wire Three Phase Motor

<p>Star Connection</p>	<p>Delta Connection</p>
<p>To change the direction, interchange any two wires between U, V & W. For 415 Volt supply, wires are connected as shown. Short White, Black & Blue wire and then insulate properly.</p>	<p>To change the direction, interchange any two wires between U, V & W. For 230 Volt 3 Ph supply, wires are connected as shown.</p>

Change the direction of the motor only after it stops rotating. If the attempt is made during rotation, motor may ignore the reversing command or change the direction after some time.